

Z-Line Low Profile Boltless Shelving Installation Instructions

Tennsco Corp., Dickson, TN 37056-1888 • (615) 446-8000

RETAIN INSTRUCTIONS FOR FUTURE REFERENCE!

Congratulations on your purchase of Z-Line Low Profile Boltless Shelving from **Tennsco!** Z-Line's interlocking keyhole design not only makes installation fast and easy but eliminates the need for clips, gussets, sway braces or other hardware commonly used in conventional shelving. This allows completely free access to your stored materials from all sides of the unit.

Z-Line Low Profile Shelving is available in a variety of heights, depths and widths for virtually any application. And starter and adder units allow for joining shelving units together.

SHELF LOAD CAPACITIES

36" wide units	600 lbs. per shelf
42" wide units	550 lbs. per shelf
48" wide units	500 lbs. per shelf

GENERAL SAFETY INFORMATION

Some parts may have sharp edges. CARE must be taken when handling the pieces to avoid injury. For safety, wear a pair of work gloves when assembling or performing any maintenance on shelving.



LIMITED WARRANTY

Tennsco warrants goods purchased hereunder to be free of defects in materials and workmanship for a period of one (1) year from the date of shipment, hereunder. This warranty shall not apply in the event goods are damaged as a result of misuse, abuse, neglect, accident, improper application, modification or repair by persons not authorized by Seller, where goods are damaged during shipment, or where the date stamps on the goods have been defaced, modified or removed. UNLESS CONSIDERED UNENFORCEABLE OR UNLAWFUL UNDER APPLICABLE LAW:

- a. ALL IMPLIED WARRANTIES, INCLUDING BUT NOT LIMITED TO WARRANTIES OR MERCHANTABILITY AND FITNESS FOR A PARTICULAR PURPOSE ARE HEREBY EXCLUDED:
- b. BUYERS REMEDY, IF ANY, FOR ANY DEFECTIVE GOODS SHALL BE LIMITED TO A REFUND BY SELLER OR REPLACEMENT OF THE GOODS AT SELLER'S OPTION, AND SHALL IN NO EVENT INCLUDE DAMAGES OF ANY KIND, WHETHER INCIDENTAL, CONSEQUENTIAL OR OTHERWISE.

NO GOODS ACCEPTED FOR RETURN WITHOUT PRIOR APPROVAL. Seller shall have the right to inspect any goods claimed to be defective at Buyers place of business or require Buyer to return the goods to Seller for inspection on Seller's premises. Transportation charges covering returned goods will be borne by Seller only if such goods are proven to be defective, are covered by this warranty and are returned within the warranty period stated above.

TENNSCO CORP., P.O. BOX 1888, DICKSON, TN 37056-1888
(615) 446-8000 (800) 251-8184

ASSEMBLY OF BOLTLESS LOW PROFILE SHELVING

Tool Needed: A rubber mallet for seating the shelf supports into the uprights. Two people recommended for assembly. Approximate assembly time: 15 to 30 minutes per shelving section.

1. The reference numbers used throughout this sheet refer to the illustration on the back cover. This is to help you to identify the various parts as they are mentioned.

2. Depending upon whether you are assembling a single unit or an adder unit, you may have one or both of the styles of upright shown at right:

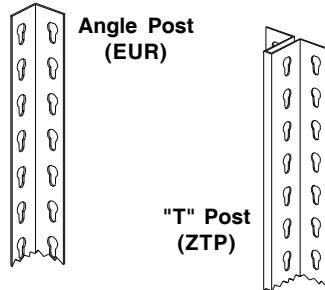

A single unit will use EUR angle posts for all four uprights, as shown below in Figure A. If you plan on assembling multiple sections, however, you should build the starter unit with two ZTP "T" posts on one end (which will provide common posts for adjacent sections), as shown in Figure B.

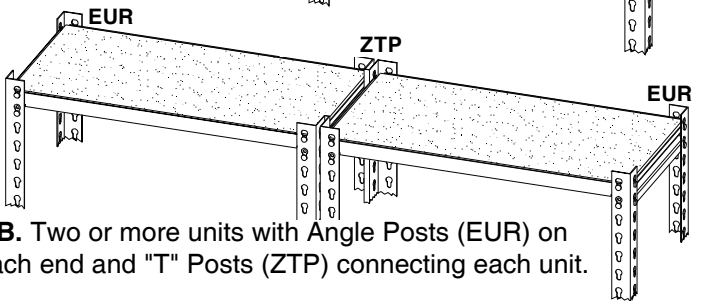

3. With help from an associate, or using a wall for support, connect two EUR uprights (Ref. No. 1a) together with two front-to-back end supports (Ref. No. 2), one at the top and one at the bottom. When inserting supports,

be sure the rivets are fully seated in the key-hole slots, as shown.

NOTE: The uprights must be positioned so that the narrow part of the slots is toward the floor, as shown in the inset.

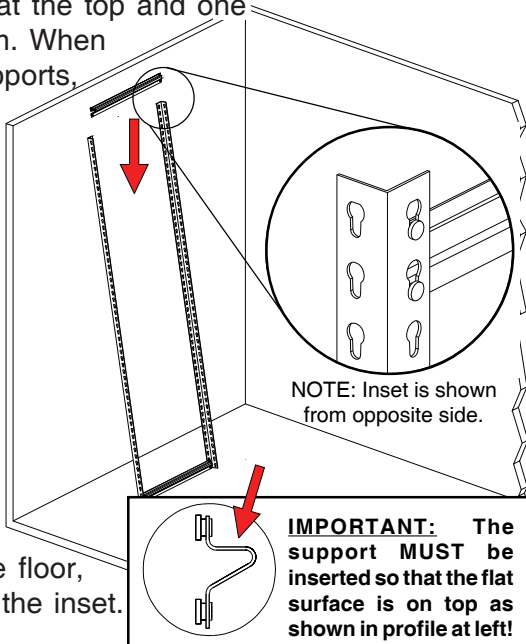

NOTE: Inset is shown from opposite side.

IMPORTANT: The support **MUST** be inserted so that the flat surface is on top as shown in profile at left!

4. Place a third front-to-back end support in the middle slots of the two uprights. This forms one end of the shelving unit.

NOTE: There will be only three (3) front-to-back end supports per unit end, as shown. These are used for rigidity and are not needed at every shelf level.

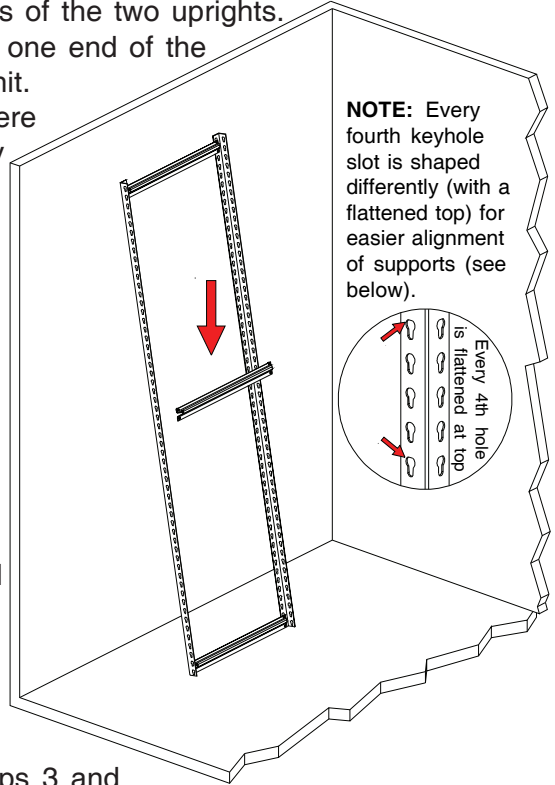

NOTE: Every fourth keyhole slot is shaped differently (with a flattened top) for easier alignment of supports (see below).

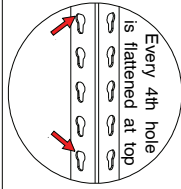

5. Repeat steps 3 and 4 to construct a second set of unit ends. **NOTE:** If you are planning to install an adder unit, this second end should consist of ZTP Uprights (Ref. No. 1b) to act as an intermediate assembly. Carefully re-read through step 2 to better understand this.

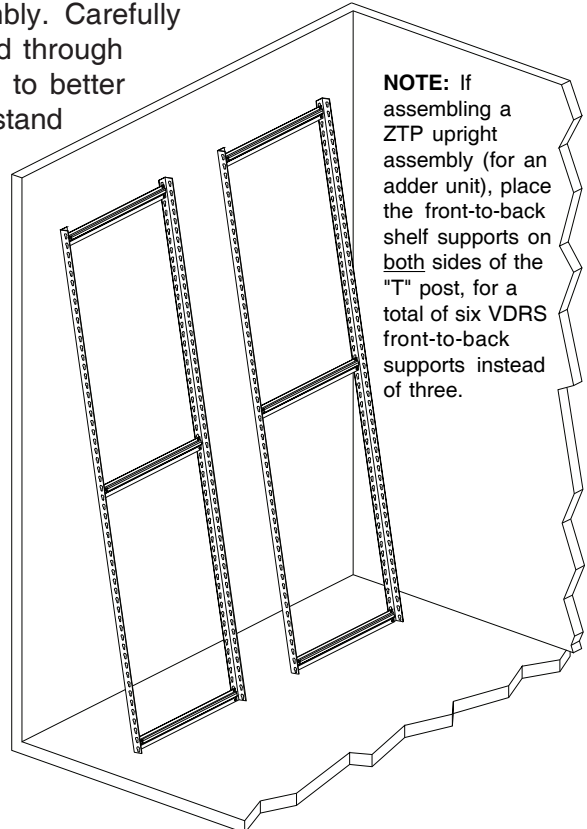

NOTE: If assembling a ZTP upright assembly (for an adder unit), place the front-to-back shelf supports on both sides of the "T" post, for a total of six VDRS front-to-back supports instead of three.

6. With the help of an associate, connect the two unit ends with left-to-right shelf supports (Ref No. 3). Be sure the shelf support is oriented as shown below.

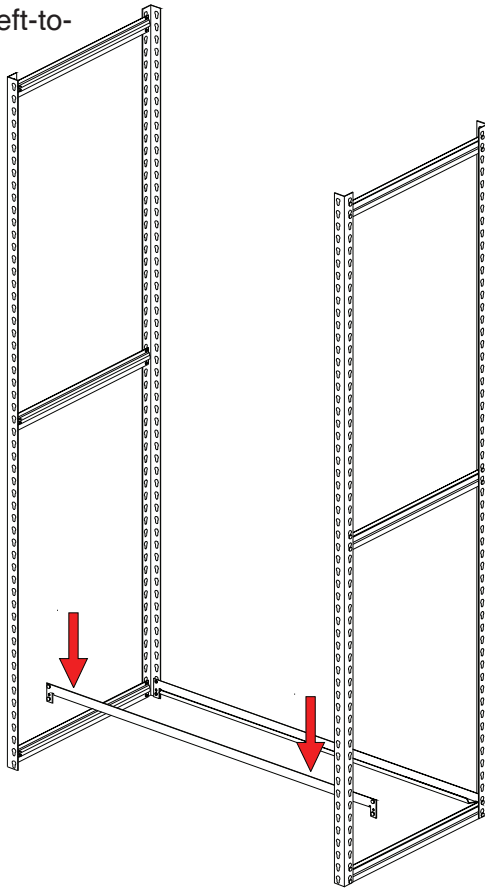
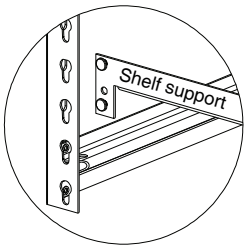

7. Attach the remaining shelf supports at the desired shelf levels.

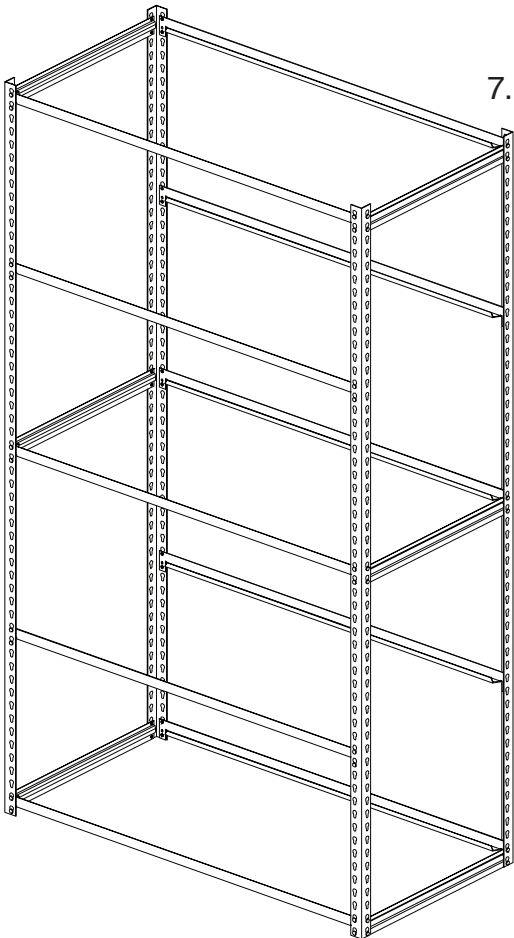

8. If particleboard or wire decking was purchased, place the decking on each shelving level. Particleboard decking should fit flush inside the shelf supports, while wire decking will sit slightly below the shelf support edges.

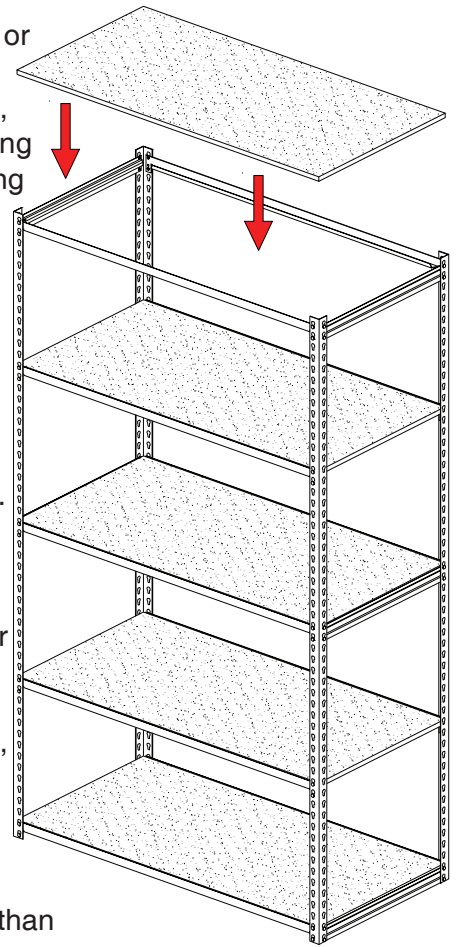

If you have purchased a single unit, your shelving unit is now complete. For adder units, see step 9.

9. If joining more than one unit together, your original unit should have been assembled with ZTP uprights on one end, as described in step 5. Simply continue adding shelf supports and uprights to complete your additional units.

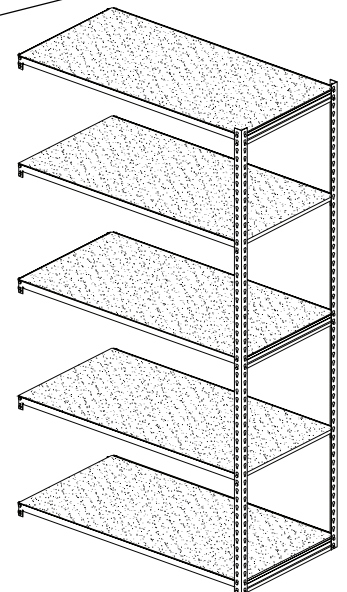
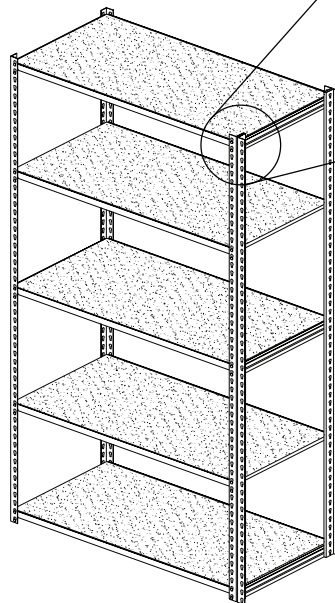
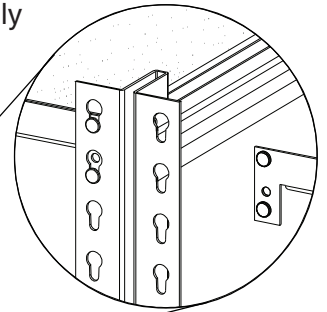

REPLACEMENT PARTS

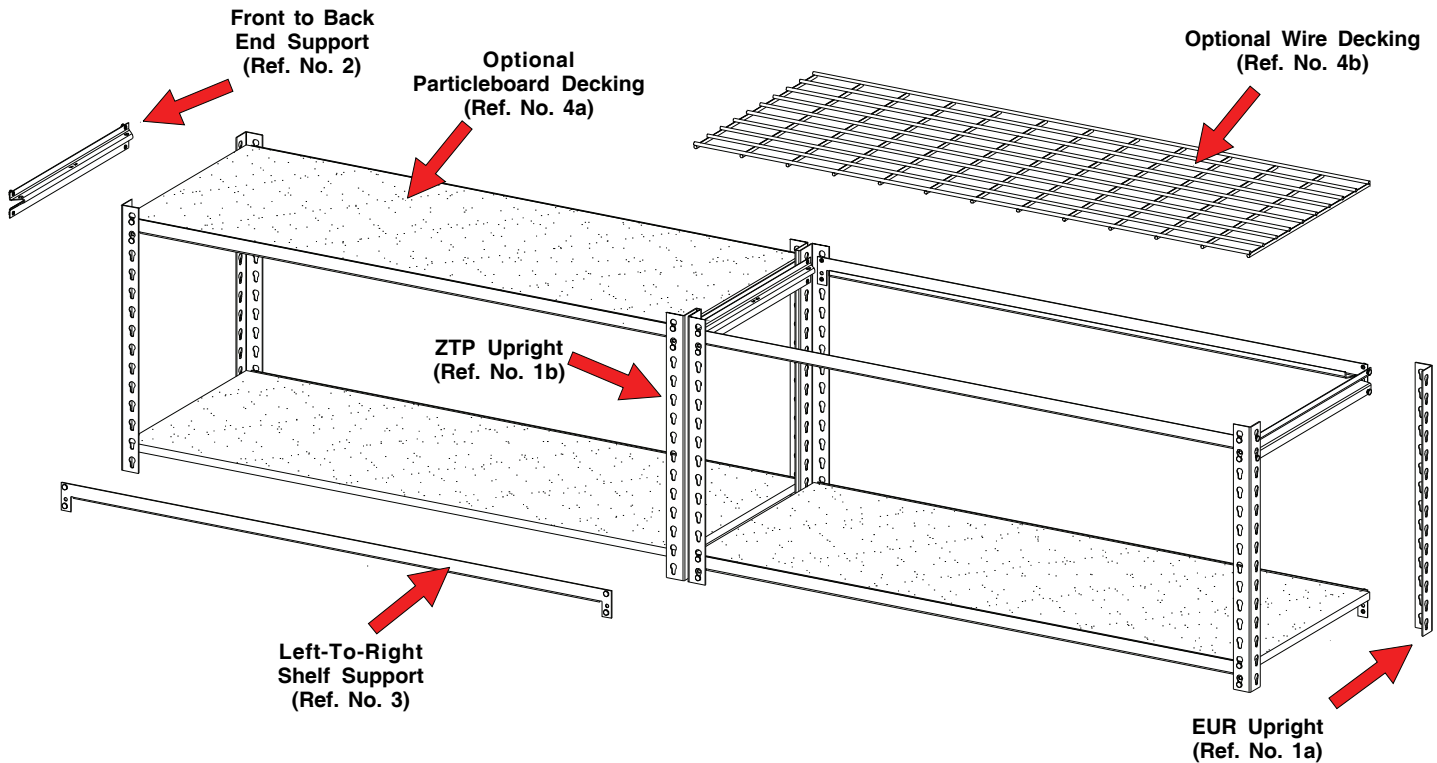

SINGLE OR STARTER UNIT				ADDER UNIT			
REF. NO.	DESCRIPTION	QTY.*	PART NO.**	REF. NO.	DESCRIPTION	QTY.*	PART NO.**
1a	Angle Post	4	EUR-hh	1b	"T" Post	2	ZTP-hh
2	Front-To-Back End Support	6	VDRS-dd16	2	Front-To-Back End Support	6	VDRS-dd16
3	Left-To-Right Shelf Support	10	DRS-ww14	3	Left-To-Right Shelf Support	10	DRS-ww14
4a	Optional Decking-Particleboard	5	PB-wwdd	4a	Optional Decking-Particleboard	5	PB-wwdd
4b	Optional Decking-Wire	5	ZWD-wwdd	4b	Optional Decking-Wire	5	ZWD-wwdd

* Quantities indicated are per five-shelf section
 ** Where the suffix "ww", "dd", or "hh" is used in the part number, the width (ww), depth (dd) or height (hh) is substituted in the part number. For example, for an 84" high Angle Post, the part number would be EUR-84.



Tennsco makes every effort to ensure that all units ship complete and arrive undamaged. However, should your unit contain missing or damaged parts, replacements may be obtained directly from us. To obtain proper replacement parts, follow the instructions below, or fill out the form at www.tennsco.com/replacement.cfm.

TO OBTAIN PROPER REPLACEMENT PARTS, PLEASE PROVIDE THE FOLLOWING INFORMATION:

- Model Number
- Description of part(s) needed and part number(s) as shown in Parts List (above)
- Color (i.e. Medium Grey, etc.)
- Was item missing, or was it damaged?
- Purchase Date
- Your company name
- Contact person's name/address/phone number
- Company the product was purchased from

Tennsco Corp., P.O. Box 1888, Dickson, TN 37056-1888 Voice: (866) 446-8686 Fax: (800) 722-0134
 If requesting parts by telephone, ask for customer service and have as much of the above information ready as possible.
 Or, if you prefer, you can fill out the parts replacement form at www.tennsco.com/replacement.cfm.